



American Made Quality since 1928



Water Gauges & Liquid Level Gauges

"Apollo" Valves

manufactured in the USA
by CONBRACO Industries

A history of Quality, Service and Innovation

Now in its ninth decade, Conbraco Industries, Inc. is a leading manufacturer of flow control products for U.S. and international markets. The company's headquarters is based in Matthews, North Carolina with manufacturing plants and foundries located in Pageland and Conway, South Carolina.

Conbraco has a history of new product development and innovation that dates back to the company's inception in 1928. Today, the Conbraco line of products is marketed under the "Apollo Valves" brand and includes: ball valves, butterfly valves, backflow prevention devices, water pressure reducing valves, mixing valves, safety relief valves, water gauges, strainers, actuation and APOLLOXPRESS® products.

Conbraco's vertically integrated manufacturing ensures a consistency of production, testing, quality and availability. You can be assured that Conbraco flow control products will deliver long term reliability. All manufacturing facilities are ISO 9001:2008 certified.

The Conbraco line continues to expand with new products, designs and advanced materials to better serve the needs of our customers. Markets served include: chemical processing, pulp and paper, petroleum, residential and commercial plumbing and heating, OEM, irrigation, water works, and fire protection.



PAGELAND, SC
Bronze Foundry and Manufacturing Plant



PAGELAND, SC
Final Assembly and Distribution Center



CONWAY, SC
Steel Foundry and Manufacturing Plant



MATTHEWS, NC
Corporate Headquarters

Table of Contents

What Is A Water Gauge?.....	3	Stainless Steel Liquid Level Gauges.....	11
How To Select A Water Gauge.....	4	Rough Bronze Liquid Level Gauges.....	12
Do's and Don't's.....	5	Polished Bronze Water Gauges.....	12
Installation.....	5	Gauge Glass Ratings.....	13,14
Available Water Gauges And Liquid Level Gauges.....	6-7	Repair Kits.....	15,16
Water Gauges Liquid Level Gauges Dimensions.....	8-9	Glossary.....	17
Rough Bronze Water Gauges.....	10	Warranty.....	19
Rough Bronze Water Gauges with Extended Shank.....	11		

WATER GAUGES AND LIQUID LEVEL GAUGES

What is a Water Gauge?

A water gauge is a device that allows the liquid level in a vessel to be visually inspected. Water gauges are required by the ASME Boiler and Pressure Code on steam boilers, and are also useful in many other applications, such as monitoring the amount of oil in an oil tank.

THINGS TO REMEMBER

Care must be given to ensure the proper selection of a water gauge. Special attention must be given to temperature/pressure requirements and to the service media (i.e. water, steam, oils, chemical agents, etc.). Some items to keep in mind:

- **PRESSURE RATINGS** may be influenced by limitations of the valve body, gauge glass, and gauge glass gasket. As temperatures increase, pressure ratings decrease. The larger the glass diameter and the longer the glass length, the lower the pressure rating. Refer to the **GAUGE GLASS PRESSURE AND TEMPERATURE TABLE** for detailed information.
- **TEMPERATURE RATINGS** may also be influenced by limitations of the valve body, gauge glass, & gauge glass gasket.
- Use **GUARD RODS** and **TUBULAR GAUGE GLASS PROTECTORS** to help protect glass from accidental breakage. Some applications require glass protectors.
- Use **REDLINE** gauge glass where pressures permit to allow for easy reading of the gauge. Use large diameter (3/4") glass for increased visibility.
- Use **AUTOMATIC BALL CHECKS** to help minimize the risk of property damage or personal injury in the event of gauge glass breakage. Vertically rising automatic ball checks conforming to ASME requirements are available.
- Boilers operating above 400 psig require two water gauges.
- All water gauges on all steam boilers must be 1/2" NPT or larger.

A SPECIAL NOTE ABOUT CORROSION

Most problems with water gauge performance are associated with corrosion. Excessive corrosion may result in leakage, glass breakage, and premature valve failure. There are several things to watch for:

- Be sure all components (valve body, seals and packings, etc.) of the water gauge are constructed with materials compatible with the service medium. Non-standard packings for special applications may be ordered in our **WATER GAUGE REPAIR KITS**. See the "Compass Corrosion Guide" or equivalent for additional information.
- Elevated temperatures and pressures accelerate corrosion (you may need a stainless steel water gauge instead of bronze, or high pressure glass instead of standard, to achieve an acceptable service life).
- Operation and maintenance - check gauges daily for leaks, corrosion, and gauge glass clarity. Water gauges should be well illuminated and kept clean. Leaks may result in false waterline readings, may damage the gauge, and accelerate corrosion. The appearance of rust in the gauge glass is an indication of improper water treatment. See the CONBRACO WATER GAUGE INSTALLATION INSTRUCTIONS (I-5387-00) or the appropriate sections of the ASME Boiler and Pressure Vessel Code for additional information.
- Gauge Glass Corrosion - Gauge glass is attacked and dissolved in service by the fluid media, resulting in thinning of the wall and premature failure or replacement. Two factors determine the rate of attack: alkalinity and temperature. High alkalinity (high pH values) increases the rate of attack (a pH of 11.5 attacks glass at a rate of 30 times greater than a pH of 8.5). High temperatures increase the rate of attack (500°F water attacks glass 100 times faster than 265°F water). There is nothing that may be done to reduce the effects of temperature, but the effects of pH may be reduced by maintaining proper pH balance in the boiler water with chemical agents. Glass corrosion may also be decreased by avoiding exposure to water spray and drafts.



WATER GAUGES AND LIQUID LEVEL GAUGES

How to Select a Water Gauge

1 SELECT A VALVE SERIES BASED UPON THE APPLICATION:

- Use 20-410 series for 90° handles or when working in close quarters.
- Use 20-600, 24-600, or 25-600 series (chain levers) where the water gauge is located beyond reach from the floor.
- Use 20-604/605 (bronze) or 23-650 (stainless steel) series expansion tank gauges when a shut-off is not required in the top valve (**NEVER USE AN EXPANSION TANK GAUGE ON A BOILER!**).
- Use 20-800 (bronze) or 23-450 (stainless steel) series expansion tank gauges to mount a pressure gauge or other instrument directly to the water gauge.
- Use 20-700 series expansion tank gauge for easier gauge glass replacement.
- Use 23-450 series stainless steel for superior corrosion resistance.
- Use polished gauges for a more elegant appearance.
- Use heavy pattern water gauges (such as 20-200/250, 24-300/350) for higher pressures. **Be sure to verify gauge glass will withstand pressure by consulting the "Gauge Glass Service Rating Table".**
- Use longer shank on NPT end when extra shank length is needed to penetrate an outer jacket or insulation (available on 21 series). Otherwise use a standard water gauge.

2 SELECT NON-AUTOMATIC, AUTOMATIC, OR ASME AUTOMATIC:

- Use automatic (horizontally seating) or ASME automatic (vertically rising to seat in lower valve body) ball checks where available to minimize the risk of personal injury and/or property damage in the event of gauge glass breakage. The sudden rush of steam and water seats the balls, thereby shutting off the escape of steam and water. There will however be slight leakage as required by certain codes.

3 SELECT A HANDWHEEL STYLE:

- Use aluminum handwheels for durability.
- Use plastic (composition) handwheels for reduced heat transfer.
- Use chain levers (not available on all models) when the water gauge is located beyond reach from the floor.

4 SELECT A GAUGE GLASS SIZE (DIAMETER):

- Use larger (3/4") diameter gauge glass where available for increased visibility.

5 SELECT A GAUGE GLASS TYPE (BASED ON PRESSURE REQUIREMENTS):

- Use Redline glass for increased fluid level visibility.
- Use high pressure glass for high pressure applications.
- For economy use standard glass for low pressure applications.
- Replace the two digit suffix in the part number of the water gauge with -10 when selecting Redline or high pressure gauge glass (23 and 24 series have high pressure glass as standard).

** Please call Customer Service when non-standard (-10) devices are required.*

6 SELECT GAUGE GLASS LENGTH:

- Select a default gauge glass length when possible (pages 8-9).
- Select a non-standard gauge glass length as needed, and replace the two digit suffix in the part number of the water gauge with -10. The longer the gauge glass, the lower the allowable pressure and temperature. Be sure to consult the "Gauge Glass Service Rating Table" for pressure and temperature limits. When selecting

non-standard gauge glass lengths, the gauge glass length is determined by subtracting the GL code from the desired "L" length for the valve series number according to the tables on pages 8 and 9.

- For gauge glass longer than 72" it is necessary to use two or more water gauges of shorter length in an overlapped staggered tandem (i.e. for 100" of needed coverage, use two gauges of about 55" and install them parallel and staggered so as to overlap their individual coverage of 55" to get 100" total coverage).

** Please call Customer Service when non-standard (-10) devices are required.*

7 SELECT TUBULAR GAUGE GLASS PROTECTOR:

- For 5/8" diameter gauge glass, use I-2733-05
- For 3/4" diameter gauge glass, use I-2734-05
- Maximum protector length is 50"
- Protector not available on 23-300, 23-650, and 24-600 series.
- Available in brass only

8 SELECT DRAIN TYPE:

- Plug drain is standard on 23-600 series. Ball valve drain is standard on 23-400/450 and 24-300/350 series. Needle drain is standard on all others. Ball valve drain or pet cock drain available on most models upon request.

9 SELECT A GAUGE GLASS PACKING MATERIAL:

- Use EPDM for most general applications, including steam service, for temperatures -20°F to 350°F. Recommended for water, steam, silicone oils, ketones (MEK, acetone, etc...), alcohol, and brake fluid. Unsuitable for petroleum oils. Comes standard on most models. EPDM is most economical.
- Use Viton® for superior resistance at elevated temperatures -15°F to 400°F (up to 600°F for short periods.) Recommended for petroleum oils, silicone oils, halogenated hydrocarbons (carbon tetrachloride, trichloroethylene), acids. Unsuitable for ketones (MEK, acetone), amines, anhydrous ammonia, hot hydrofluoric or chlorosulfonic acid. Viton® is about ten times more expensive than EPDM. ** Not recommended for use with steam.*
- Use Hypalon® for superior acid resistance at temperatures -20°F to 450°F. Has a shorter service life than EPDM and Viton® in standard, non-acid applications. More difficult to seal than softer EPDM or Viton®. Comes standard on 23 and 24 series. Hypalon® is equivalent to EPDM in cost.
- Use Teflon® for best chemical resistance, for temperatures up to 450°F. More difficult to seal than Hypalon®, Viton®, or EPDM. Use only when needed for more chemical resistance than Viton® at elevated temperatures. Not recommended for hot fluorine, oxygen difluoride, or chlorine trifluoride. Teflon® is about three times as expensive as EPDM.
- Use Graphite for superior service at elevated temperatures. More difficult to seal than EPDM or Viton® but has more universal application. Graphite is about ten times more expensive than EPDM.
- Remember, chemical resistance decreases as temperature increases. Consult "Compass Corrosion Guide" or equivalent.
- To order non-standard gauge glass packing, order the water gauge normally, then also order a "Water Gauge Repair Kit" ("Standard All" for EPDM, Hypalon® and Teflon®; "Viton® Gaskets Only" for Viton®, and "Graphite Gaskets Only" for graphite). Remove the pre-installed packing, and install the desired packing material.

WATER GAUGES AND LIQUID LEVEL GAUGES

Water Gauge Dos and Don'ts

DO NOT'S

- **DO NOT** use glass if it contains any scratches, chips, or any other visible signs of damage.
- **DO NOT** reuse any tubular glass or glass packings.
- **DO NOT** subject gauge glass to bending or torsional stresses.
- **DO NOT** over tighten glass packing nuts.
- **DO NOT** allow glass to touch any metal parts.
- **DO NOT** exceed the recommended pressure of the gauge or gauge glass.
- **DO NOT** clean the gauge or gauge glass while pressurized or in operation.

DO'S

- **DO** verify proper gauge has been supplied.
- **DO** examine gauge glass and packings carefully for damage before installation.
- **DO** install protective guards and utilize automatic ball checks where necessary to help prevent injury in case of glass breakage.
- **DO** inspect the gauge glass daily, keep maintenance records, and conduct routine replacements.
- **DO** protect glass from sudden changes in temperatures such as drafts, water spray, etc.

Installation

Only properly trained personnel should install and maintain water gauge glass and connections. Remember to wear safety gloves and glasses during installation. Before installing, make sure all parts are free of chips and debris.

- 1 Apply Teflon® tape or pipe dope to pipe threads. Install top gauge fitting (fitting without a drain valve) into the upper most tapping. Wrench tighten the fitting until it is snug and the glass outlet is pointing at five o'clock (about 1/8 turn from its final, downward vertical, position).
- 2 Install the bottom gauge fitting (the fitting with a drain valve) until it is snug and the glass outlet is pointing directly upward. Verify top and bottom fittings are threaded into the tappings the same number of turns (distance A= distance B).
- 3 Remove glass packing nut, friction washer (or packing gland and retaining ring, depending upon the model), and glass packing from the fittings, and place them, in the same order, on to both ends of the gauge glass. Push both packings about an inch up the gauge glass.
- 4 Gently insert one end of the glass into the top gauge fitting. Keeping the glass inside the top fitting, gently rotate the top gauge fitting clockwise, using wrench on valve wrench flats, until vertically aligned with the bottom gauge fitting, then insert glass into bottom fitting until glass bottoms out on the shoulder inside the bottom fitting.

MAINTENANCE

Examine the gauge glass regularly for any signs of clouding, scratching, erosion, or corrosion. The glass should be inspected daily until the need for replacement becomes apparent. This will help establish the routine inspection and routine replacement schedules.

CLEANING

Use commercial non-abrasive glass cleaners to keep glass clean. Use diluted acids such as Hydrochloric (muriatic) acid when regular cleaners do not seem to work. Do not use wire brushes or any other abrasive materials which could scratch the glass.

INSPECTION

Examine the surface of the glass for scratches, corrosion, chips, cracks, surface flaws, or nicks. To do this, aim a very bright concentrated light at an angle of about 45 degrees. A defective glass will glisten as the light strikes imperfections. Glass which appears cloudy or roughened, and will not respond to cleaning, should be replaced.

STORING

Keep gauge glass in original packaging until ready to install.

- 5 Carefully raise glass about 1/16" and slide lower glass packing down until the glass packing contacts the lower gauge fitting. **DO NOT** allow the glass to remain in contact with any metal!
- 6 Carefully slide upper glass packing up as far as possible.
- 7 Hand tighten both glass packing nuts, then tighten 1/2 turn more by wrench. Tighten only enough to prevent leakage. **DO NOT OVER TIGHTEN!** If any leakage should occur, tighten slightly, a quarter turn at a time, checking for leakage after each turn.

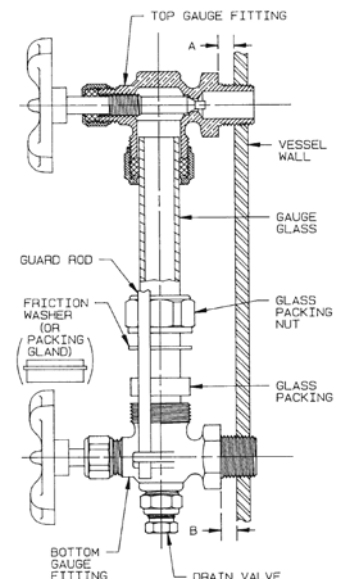

WATER GAUGES AND LIQUID LEVEL GAUGES

Available Water Gauges

20-100 Series
Standard Pattern



20-150 Standard
Pattern Automatic



20-200 Series
Heavy Pattern



20-250 Heavy
Pattern Automatic



20-300 Series



20-350 Series
Automatic



20-410 Series
Left Hand Only



20-601 & 602 Series



20-604 & 20-605 Series



WATER GAUGES AND LIQUID LEVEL GAUGES

Available Water Gauges

20-700 Series



20-800 Series



23-450 Series
ASME Automatic



23-600 Series



24-300 Series



24-600 Series



25-200 Series
Heavy Pattern



25-400 Series



25-500 Series
Automatic

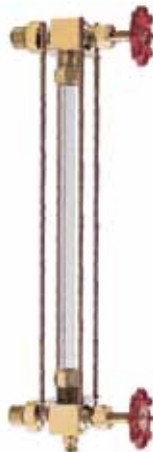

25-600 Series



WATER GAUGES AND LIQUID LEVEL GAUGES

Dimensions

- A = Overall length is found by adding this to dimension "L"
- B = Valve open total depth
- C = Valve closed total depth
- D = Handle diameter
- E = Maximum extension below lower arm centerline
- F = Maximum extension above upper arm centerline
- G = End of arm NPT to centerline of glass
- H = End of arm NPT to hex shoulder
- L = Centerline Length

Glass Length is "L" minus GL code
Rod Length is glass length plus RL code

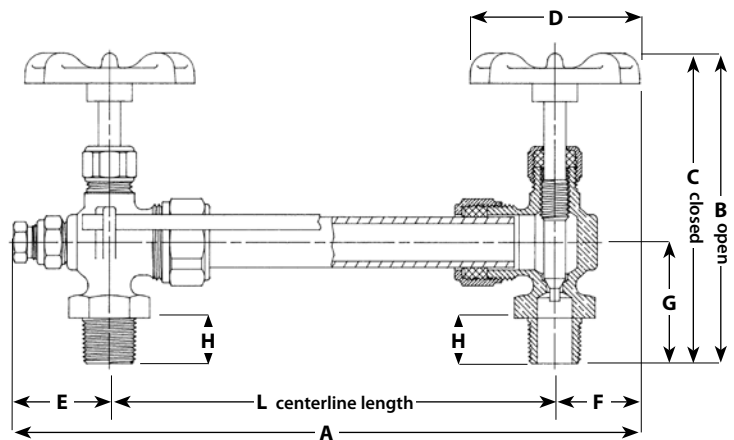

Valve	Pipe Size	A	B	C	D	E	F	G	H	Default L	Default Glass Length	GL Code	RL Code
20-101	3/8	2.3	4.1	3.8	2.1	1.25	1.07	1.50	0.56	11.25	10	1.25	2
20-102	3/8	2.3	4.3	4.1	2.0	1.25	1.00	1.50	0.56	11.25	10	1.25	2
20-104	1/2	2.3	4.2	3.9	2.1	1.25	1.07	1.63	0.69	13.25	12	1.25	2
20-105	1/2	2.3	4.4	4.2	2.0	1.25	1.00	1.63	0.69	13.25	12	1.25	2
20-150*	1/2	2.3	4.2	3.9	2.1	1.25	1.07	1.63	0.69	13.25	12	1.25	2
20-151*	1/2	2.3	4.4	4.2	2.0	1.25	1.00	1.63	0.69	13.25	12	1.25	2
20-201	3/8	2.4	4.4	4.2	2.1	1.38	1.07	1.69	0.56	11.25	10	1.25	2
20-202	3/8	2.4	4.4	4.1	2.0	1.38	1.00	1.69	0.56	11.25	10	1.25	2
20-204	1/2	2.4	4.6	4.3	2.1	1.38	1.07	1.81	0.69	13.25	12	1.25	2
20-205	1/2	2.4	4.5	4.3	2.0	1.38	1.00	1.81	0.69	13.25	12	1.25	2
20-207	3/4	2.4	4.9	4.6	2.1	1.38	1.07	2.05	0.75	17.50	16	1.50	2.25
20-208	3/4	2.4	5.1	4.8	2.0	1.38	1.00	2.05	0.75	17.5	16	1.50	2.25
20-250	1/2	2.4	4.6	4.3	2.1	1.38	1.07	1.81	0.69	13.25	12	1.25	2
20-251*	1/2	2.4	4.5	4.3	2.0	1.38	1.00	1.81	0.69	13.25	12	1.25	2
20-253*	3/4	2.4	4.9	4.6	2.1	1.38	1.07	2.05	0.75	17.50	16	1.50	2.25
20-254*	3/4	2.4	5.1	4.8	2.0	1.38	1.00	2.05	0.75	17.50	16	1.50	2.25
20-304	1/2	2.3	5.3	5.1	2.1	1.25	1.07	2.20	0.69	14	12	2.00	1.25
20-305	1/2	2.3	5.5	5.3	2.0	1.25	1.00	2.20	0.69	14	12	2.00	1.25
20-307	3/4	2.3	5.0	5.4	2.1	1.25	1.07	2.06	0.69	18	16	2.00	1.25
20-308	3/4	2.3	5.4	5.0	2.0	1.25	1.00	2.06	0.69	18	16	2.00	1.25
20-350*	1/2	2.3	5.3	5.1	2.1	1.25	1.07	2.20	0.69	14	12	2.00	1.25
20-351*	1/2	2.3	5.5	5.3	2.0	1.25	1.00	2.20	0.69	14	12	2.00	1.25
20-353*	3/4	2.3	5.0	5.4	2.1	1.25	1.07	2.06	0.69	18	16	2.00	1.25
20-354*	3/4	2.3	5.4	5.0	2.0	1.25	1.00	2.06	0.69	18	16	2.00	1.25
20-410	1/2	2.3	2.1	1.9	1.8	1.42	0.86	2.09	1.25	13.25	12	1.25	NA
20-601	1/2	4.2	5.3	4.8	5.9	1.25	2.94	2.09	0.69	14	12	2.00	1.25
20-602	3/4	4.2	5.3	4.8	5.9	1.25	2.94	2.09	0.69	18	16	2.00	1.25
20-604*	1/2	2.1	4.6	4.3	2.1	1.38	0.69	1.81	0.69	13.25	12	1.25	2
20-605*	1/2	2.1	4.5	4.3	2.0	1.38	0.69	1.81	0.69	13.25	12	1.25	2
20-703	3/8	1.8	NA	NA	NA	1.25	0.53	1.50	0.56	11.25	10	1.25	2
20-704	1/2	1.8	NA	NA	NA	1.25	0.53	1.63	0.69	13.25	12	1.25	2
20-804*	1/2	2.1	4.6	4.3	2.1	1.38	0.75	1.81	0.69	13.25	12	1.25	2
20-805*	1/2	2.1	4.5	4.3	2.0	1.38	0.75	1.81	0.69	13.25	12	1.25	2
21-104	1/2	2.3	5.3	5.1	2.1	1.25	1.07	2.69	1.75	13.25	12	1.25	2
21-105	1/2	2.3	5.5	5.3	2.0	1.25	1.00	2.69	1.75	13.25	12	1.25	2

WATER GAUGES AND LIQUID LEVEL GAUGES

Dimensions (cont'd)

Valve	Pipe Size	A	B	C	D	E	F	G	H	Default L	Default Glass Length	GL Code	RL Code
21-150*	1/2	2.3	5.0	4.8	2.1	1.25	1.07	2.69	1.75	13.25	12	1.25	2
21-151*	1/2	2.3	5.5	5.3	2.0	1.25	1.00	2.69	1.75	13.25	12	1.25	2
21-204	1/2	2.4	5.6	5.4	2.1	1.38	1.07	2.88	1.75	13.25	12	1.25	2
21-205	1/2	2.4	5.6	5.3	2.0	1.38	1.00	2.88	1.75	13.25	12	1.25	2
21-250*	1/2	2.4	5.6	5.4	2.1	1.38	1.07	2.88	1.75	13.25	12	1.25	2
21-251*	1/2	2.4	5.6	5.4	2.0	1.38	1.00	2.88	1.75	13.25	12	1.25	2
23-401	1/2	4.1	5.6	5.6	2.1	3	1.07	2.13	0.69	14	12	2	3.25
23-402	1/2	4.0	5.6	5.6	2.0	3	1.00	2.13	0.69	14	12	2	3.25
23-404	3/4	4.1	5.6	5.1	2.1	3	1.07	2.09	0.75	18	16	2	3.25
23-405	3/4	4.0	5.6	5.1	2.0	3	1.00	2.09	0.75	18	16	2	3.25
23-450**	1/2	4.1	5.6	5.1	2.1	3	1.07	2.13	0.69	14	12	2	3.25
23-451**	1/2	4.0	5.6	5.1	2.0	3	1.00	2.13	0.69	14	12	2	3.25
23-453**	3/4	4.1	5.6	5.1	2.1	3	1.07	2.09	0.75	18	16	2	3.25
23-454**	3/4	4.0	5.6	5.1	2.0	3	1.00	2.09	0.75	18	16	2	3.25
23-651	1/2	1.8	4.6	4.4	2.1	1.065	0.69	2.50	0.69	14	12	2	1.25
23-654	3/4	1.8	4.6	4.4	2.1	1.065	0.69	2.50	0.75	14	12	2	1.25
24-301	1/2	4.1	5.8	5.3	2.1	3	1.07	2.09	0.69	14	12	2	1.25
24-302	1/2	4.0	5.8	5.3	2.0	3	1.00	2.09	0.69	14	12	2	1.25
24-304	3/4	4.1	5.8	5.3	2.1	3	1.07	2.09	0.69	18	16	2	1.25
24-305	3/4	4.0	5.6	5.1	2.0	3	1.00	2.09	0.69	18	16	2	1.25
24-350**	1/2	4.1	5.8	5.3	2.1	3	1.07	2.09	0.69	14	12	2	1.25
24-351**	1/2	4.0	5.6	5.1	2.0	3	1.00	2.09	0.69	14	12	2	1.25
24-353**	3/4	4.1	5.8	5.3	2.1	3	1.07	2.09	0.69	18	16	2	1.25
24-354**	3/4	4.0	5.6	5.1	2.0	3	1.00	2.09	0.69	18	16	2	1.25
24-601	1/2	5.9	5.3	4.8	5.8	3	2.88	2.09	0.69	14	12	2	0.875
24-602	3/4	5.9	5.3	4.8	5.8	3	2.88	2.09	0.69	18	16	2	0.875
24-651**	1/2	5.9	5.3	4.8	5.8	3	2.88	2.09	0.69	14	12	2	0.875
24-652**	3/4	5.9	5.3	4.8	5.8	3	2.88	2.09	0.69	18	16	2	0.875
25-201	3/8	2.4	4.4	4.2	2.1	1.38	1.07	1.69	0.56	11.25	10	1.25	2
25-202	3/8	2.4	4.4	4.1	2.0	1.38	1.00	1.69	0.56	11.25	10	1.25	2
25-204	1/2	2.4	4.6	4.3	2.1	1.38	1.07	1.81	0.69	13.25	12	1.25	2
25-205	1/2	2.4	4.5	4.3	2.0	1.38	1.00	1.81	0.69	13.25	12	1.25	2
25-207	3/4	2.4	4.9	4.6	2.1	1.38	1.07	2.05	0.75	17.25	16	1.25	2
25-208	3/4	2.4	5.1	4.8	2.0	1.38	1.00	2.05	0.75	17.25	16	1.25	2
25-404	1/2	2.3	5.3	5.1	2.1	1.25	1.07	2.20	0.69	14	12	2	1.25
25-405	1/2	2.3	5.5	5.3	2.0	1.25	1.00	2.20	0.69	14	12	2	1.25
25-407	3/4	2.3	5.4	5.0	2.1	1.25	1.07	2.06	0.69	18	16	2	1.25
25-408	3/4	2.3	5.4	5.0	2.0	1.25	1.00	2.06	0.69	18	16	2	1.25
25-501*	1/2	2.3	5.3	5.1	2.1	1.25	1.07	2.20	0.69	14	12	2	1.25
25-502*	1/2	2.3	5.5	5.3	2.0	1.25	1.00	2.20	0.69	14	12	2	1.25
25-504*	3/4	2.3	5.4	5.0	2.1	1.25	1.07	2.06	0.69	18	16	2	1.25
25-505*	3/4	2.3	5.4	5.0	2.0	1.25	1.00	2.06	0.69	18	16	2	1.25
25-601	1/2	5.9	5.3	4.8	5.9	2.94	2.94	2.09	0.69	14	12	2	1.25
25-602	3/4	5.9	5.3	4.8	5.9	2.94	2.94	2.09	0.69	18	16	2	1.25

* Automatic

** ASME Automatic

SUFFIX KEY

- 00 Standard set includes top & bottom valves, glass and rods
- 01 Top valve only
- 02 Bottom valve only
- 03 Top & Bottom valves only (no glass or rods)
- 10 For special gauges with non-standard glass, rods, and/or gaskets.



For additional information, submittal sheets and manuals, visit www.apollovalves.com

Customer Service (704) 841-6000

WATER GAUGES AND LIQUID LEVEL GAUGES

ROUGH BRONZE WATER GAUGES



Series No.	Rating (subject to limitation of gauge glass)
20-100	125 psig @ 350°F, 300 psig @ 100°F
20-150	125 psig @ 350°F, 300 psig @ 100°F
20-200	200 psig @ 400°F, 400 psig @ 100°F
20-250	200 psig @ 400°F, 400 psig @ 100°F
20-300	200 psig @ 400°F, 400 psig @ 100°F
20-350	200 psig @ 400°F, 400 psig @ 100°F
20-410	125 psig @ 350°F, 300 psig @ 100°F
20-601, 602	250 psig @ 400°F, 500 psig @ 100°F
20-604, 605	200 psig @ 400°F, 400 psig @ 100°F
20-700	125 psig @ 350°F, 300 psig @ 100°F
20-100	200 psig @ 400°F, 400 psig @ 100°F

Series No.	Pipe Size	Standard Glass O.D. & Length	Glass Seal	Stem Packing	Standard Glass Type	Handle	Wt./100
20-101-00	3/8	5/8 x 10	EPDM Rubber	Teflon®	Regular	Aluminum	145
20-102-00	3/8	5/8 x 10	EPDM Rubber	Teflon®	Regular	Composite	145
20-104-00	1/2	5/8 x 12	EPDM Rubber	Teflon®	Regular	Aluminum	160
20-105-00	1/2	5/8 x 12	EPDM Rubber	Teflon®	Regular	Composite	160
20-150-00*	1/2	5/8 x 12	EPDM Rubber	Teflon®	Regular	Aluminum	160
20-151-00*	1/2	5/8 x 12	EPDM Rubber	Teflon®	Regular	Composite	160
20-201-00	3/8	5/8 x 10	EPDM Rubber	Teflon®	Regular	Aluminum	185
20-202-00	3/8	5/8 x 10	EPDM Rubber	Teflon®	Regular	Composite	189
20-204-00	1/2	5/8 x 12	EPDM Rubber	Teflon®	Regular	Aluminum	205
20-205-00	1/2	5/8 x 12	EPDM Rubber	Teflon®	Regular	Composite	205
20-207-00	3/4	3/4 x 16	EPDM Rubber	Teflon®	Regular	Aluminum	270
20-208-00	3/4	3/4 x 16	EPDM Rubber	Teflon®	Regular	Composite	270
20-250-00*	1/2	5/8 x 12	EPDM Rubber	Teflon®	Regular	Aluminum	195
20-251-00*	1/2	5/8 x 12	EPDM Rubber	Teflon®	Regular	Composite	200
20-253-00*	3/4	3/4 x 16	EPDM Rubber	Teflon®	Regular	Aluminum	355
20-254-00*	3/4	3/4 x 16	EPDM Rubber	Teflon®	Regular	Composite	360
20-304-00	1/2	5/8 x 12	EPDM Rubber	Teflon®	Regular	Aluminum	260
20-305-00	1/2	5/8 x 12	EPDM Rubber	Teflon®	Regular	Composite	270
20-307-00	3/4	3/4 x 16	EPDM Rubber	Teflon®	Regular	Aluminum	345
20-308-00	3/4	3/4 x 16	EPDM Rubber	Teflon®	Regular	Composite	365
20-350-00*	1/2	5/8 x 12	EPDM Rubber	Teflon®	Regular	Aluminum	265
20-351-00*	1/2	5/8 x 12	EPDM Rubber	Teflon®	Regular	Composite	265
20-353-00*	3/4	3/4 x 16	EPDM Rubber	Teflon®	Regular	Aluminum	360
20-354-00*	3/4	3/4 x 16	EPDM Rubber	Teflon®	Regular	Composite	365
20-410-00 (LH)	1/2	5/8 x 12	EPDM Rubber	Teflon®	Regular	Aluminum	180
20-601-00	1/2	5/8 x 12	EPDM Rubber	Teflon®	Regular	Chain	370
20-602-00	3/4	3/4 x 16	EPDM Rubber	Teflon®	Regular	Chain	435
20-604-00*	1/2	5/8 x 12	EPDM Rubber	Teflon®	Regular	Aluminum	155
20-605-00*	1/2	5/8 x 12	EPDM Rubber	Teflon®	Regular	Composite	175
20-703-00	3/8	5/8 x 10	EPDM Rubber	N/A	Regular	N/A	120
20-704-00	1/2	5/8 x 12	EPDM Rubber	N/A	Regular	N/A	135
20-804-00*	1/2	5/8 x 12	EPDM Rubber	Teflon®	Regular	Aluminum	160
20-805-00*	1/2	5/8 x 12	EPDM Rubber	Teflon®	Regular	Composite	160

* Automatic

Teflon® is a registered trademark of DuPont.

WATER GAUGES AND LIQUID LEVEL GAUGES

ROUGH BRONZE WATER GAUGES WITH EXTENDED SHANK



Series No.	Rating (subject to limitation of gauge glass)
21-100	125 psig @ 350°F, 300 psig @ 100°F
21-150	125 psig @ 350°F, 300 psig @ 100°F
21-200	200 psig @ 400°F, 400 psig @ 100°F
21-250	200 psig @ 400°F, 400 psig @ 100°F

Series No.	Pipe Size	Standard Glass O.D. & Length	Glass Seal	Stem Packing	Handle	Standard Glass Type	Wt./100	Shank Length
21-104	1/2	5/8 x 12	EPDM Rubber	Teflon®	Aluminum	Regular	185	1-3/4
21-105	1/2	5/8 x 12	EPDM Rubber	Teflon®	Composite	Regular	197	1-3/4
21-150*	1/2	5/8 x 12	EPDM Rubber	Teflon®	Aluminum	Regular	195	1-3/4
21-151*	1/2	5/8 x 12	EPDM Rubber	Teflon®	Composite	Regular	207	1-3/4
21-204	1/2	5/8 x 12	EPDM Rubber	Teflon®	Aluminum	Regular	215	1-3/4
21-205	1/2	5/8 x 12	EPDM Rubber	Teflon®	Composite	Regular	219	1-3/4
21-250*	1/2	5/8 x 12	EPDM Rubber	Teflon®	Aluminum	Regular	215	1-3/4
21-251*	1/2	5/8 x 12	EPDM Rubber	Teflon®	Composite	Regular	215	1-3/4

* Automatic

Teflon® is a registered trademark of DuPont.

STAINLESS STEEL LIQUID LEVEL GAUGE



Series No.	Rating (subject to limitation of gauge glass)
23-401	500 psig @ 450°F
23-450	500 psig @ 450°F
23-650	250 psig @ 406°F

Series No.	Pipe Size	Standard Glass O.D. & Length	Glass Seal	Stem Packing	Handle	Standard Glass Type	Wt./100
23-401	1/2	5/8 x 12	PTFE w/Hypalon®	Braided PTFE w/Aramid	Aluminum	High Pressure	385
23-402	1/2	5/8 x 12	PTFE w/Hypalon®	Braided PTFE w/Aramid	Composition	High Pressure	385
23-404	3/4	3/4 x 16	PTFE w/Hypalon®	Braided PTFE w/Aramid	Aluminum	High Pressure	450
23-405	3/4	3/4 x 16	PTFE w/Hypalon®	Braided PTFE w/Aramid	Composition	High Pressure	450
23-450**	1/2	5/8 x 12	PTFE w/Hypalon®	Braided PTFE w/Aramid	Aluminum	High Pressure	390
23-451**	1/2	5/8 x 12	PTFE w/Hypalon®	Braided PTFE w/Aramid	Composition	High Pressure	390
23-453**	3/4	3/4 x 16	PTFE w/Hypalon®	Braided PTFE w/Aramid	Aluminum	High Pressure	455
23-454**	3/4	3/4 x 16	PTFE w/Hypalon®	Braided PTFE w/Aramid	Composition	High Pressure	455
23-651	1/2	5/8 x 12	PTFE w/Hypalon®	Teflon®	Aluminum	High Pressure	225
23-654	3/4	5/8 x 12	PTFE w/Hypalon®	Teflon®	Aluminum	High Pressure	225

** ASME Automatic

Teflon® and Hypalon® are registered trademarks of DuPont.



For additional information, submittal sheets and manuals, visit www.apollovalves.com

Customer Service (704) 841-6000

WATER GAUGES AND LIQUID LEVEL GAUGES

ROUGH BRONZE LIQUID LEVEL GAUGE



Series No.	Rating (subject to limitation of gauge glass)
24-300	250 psig @ 400°F, 500 psig @ 100°F
24-350	250 psig @ 400°F, 500 psig @ 100°F
24-600	250 psig @ 400°F, 500 psig @ 100°F
24-650	250 psig @ 400°F, 500 psig @ 100°F
24-750	250 psig @ 400°F, 500 psig @ 100°F
24-850	250 psig @ 400°F, 500 psig @ 100°F

Series No.	Pipe Size	Standard Glass O.D. & Length	Glass Seal	Stem Packing	Handle	Standard Glass Type	Wt./100
24-301	1/2	5/8 x 12	PTFE w/Hypalon®	Braided PTFE w/Aramid	Aluminum	High Pressure	425
24-302	1/2	5/8 x 12	PTFE w/Hypalon®	Braided PTFE w/Aramid	Composition	High Pressure	425
24-304	3/4	3/4 x 16	PTFE w/Hypalon®	Braided PTFE w/Aramid	Aluminum	High Pressure	490
24-305	3/4	3/4 x 16	PTFE w/Hypalon®	Braided PTFE w/Aramid	Composition	High Pressure	490
24-350**	1/2	5/8 x 12	PTFE w/Hypalon®	Braided PTFE w/Aramid	Aluminum	High Pressure	425
24-351**	1/2	5/8 x 12	PTFE w/Hypalon®	Braided PTFE w/Aramid	Composition	High Pressure	425
24-353**	3/4	3/4 x 16	PTFE w/Hypalon®	Braided PTFE w/Aramid	Aluminum	High Pressure	490
24-354**	3/4	3/4 x 16	PTFE w/Hypalon®	Braided PTFE w/Aramid	Composition	High Pressure	490
24-601	1/2	5/8 x 12	PTFE w/Hypalon®	Braided PTFE w/Aramid	Chain	High Pressure	515
24-602	3/4	3/4 x 16	PTFE w/Hypalon®	Braided PTFE w/Aramid	Chain	High Pressure	580
24-651**	1/2	5/8 x 12	PTFE w/Hypalon®	Braided PTFE w/Aramid	Chain	High Pressure	515
24-652**	3/4	3/4 x 16	PTFE w/Hypalon®	Braided PTFE w/Aramid	Chain	High Pressure	580

** ASME Automatic

Hypalon® is a registered trademark of DuPont.

POLISHED BRONZE WATER GAUGE



Series No.	Rating (subject to limitation of gauge glass)
25-200	200 psig @ 400°F, 400 psig @ 100°F
25-400	125 psig @ 350°F, 300 psig @ 100°F
25-500	200 psig @ 400°F, 400 psig @ 100°F
25-600	250 psig @ 400°F, 500 psig @ 100°F

Series No.	Pipe Size	Standard Glass O.D. & Length	Glass Seal	Stem Packing	Handle	Standard Glass Type	Wt./100
25-201	3/8	5/8 x 10	EPDM rubber	PTFE w/Hypalon®	Aluminum	Regular	180
25-202	3/8	5/8 x 10	EPDM rubber	PTFE w/Hypalon®	Composition	Regular	185
25-204	1/2	5/8 x 12	EPDM rubber	PTFE w/Hypalon®	Aluminum	Regular	190
25-205	1/2	5/8 x 12	EPDM rubber	PTFE w/Hypalon®	Composition	Regular	190
25-207	3/4	3/4 x 16	EPDM rubber	PTFE w/Hypalon®	Aluminum	Regular	290
25-208	3/4	3/4 x 16	EPDM rubber	PTFE w/Hypalon®	Composition	Regular	295
25-404#	1/2	5/8 x 12	EPDM rubber	PTFE w/Hypalon®	Aluminum	Regular	285
25-405#	1/2	5/8 x 12	EPDM rubber	PTFE w/Hypalon®	Composition	Regular	285
25-407	3/4	3/4 x 16	EPDM rubber	PTFE w/Hypalon®	Aluminum	Regular	350
25-408	3/4	3/4 x 16	EPDM rubber	PTFE w/Hypalon®	Composition	Regular	350
25-501*	1/2	5/8 x 12	EPDM rubber	PTFE w/Hypalon®	Aluminum	Regular	290
25-502*	1/2	5/8 x 12	EPDM rubber	PTFE w/Hypalon®	Composition	Regular	290
25-504*	3/4	3/4 x 16	EPDM rubber	PTFE w/Hypalon®	Aluminum	Regular	355
25-505*	3/4	3/4 x 16	EPDM rubber	PTFE w/Hypalon®	Composition	Regular	355
25-601	1/2	5/8 x 12	EPDM rubber	Graphite w/Aramid	Chain	Regular	335
25-602	3/4	3/4 x 16	EPDM rubber	Graphite w/Aramid	Chain	Regular	350

* Automatic

Valve bodies made from brass bar stock.

Hypalon® is a registered trademark of DuPont.

www.apollovalves.com

Customer Service (704) 841-6000



WATER GAUGES AND LIQUID LEVEL GAUGES

Tubular Gauge Glass Protector

- Reduces the risk of injury and damage from broken exploding glass.
- Made to fit most water gauges.
- Priced according to length and application.
- Maximum protector length of 50".
- Tubular gauge glass protector not available on the 23-400, 23-650, 24-300, 24-350, and 24-600 series.
- Maximum of 50" length

Give series number and centerline distance
"L" when ordering.

Part Number	Size	Length
I-2733-05	5/8" O.D. glass	Up to 12" long
I-2733-05L	5/8" O.D. glass	12" to 24" long
I-2734-05	3/4" O.D. glass	Up to 16" long
I-2734-05L	3/4" O.D. glass	16" to 24" long

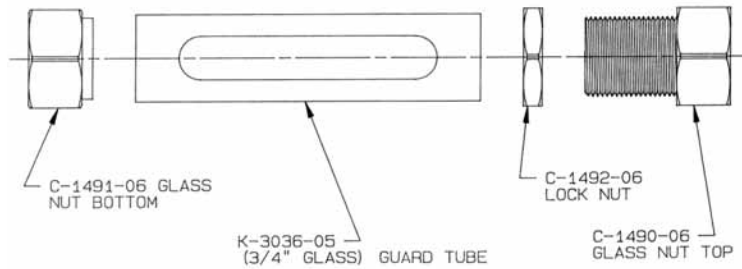

WATER GAUGES AND LIQUID LEVEL GAUGES

Gauge Pressure-Temperature Ratings

Type	OD Size	Tol	Wall	Maximum Recommended Working Pressure (psi)			
				Tol	Length	Temp. to 150°F	Steam Boiler
Standard	5/8	+0, -3/64	5/64	+1/64	8	210	100
Standard	5/8	+0, -3/64	5/64	+1/64	10	210	100
Standard	5/8	+0, -3/64	5/64	+1/64	12	205	100
Standard	5/8	+0, -3/64	5/64	+1/64	14	200	100
Standard	5/8	+0, -3/64	5/64	+1/64	16	195	100
Standard	5/8	+0, -3/64	5/64	+1/64	18	190	100
Standard	5/8	+0, -3/64	5/64	+1/64	24	180	100
Standard	5/8	+0, -3/64	5/64	+1/64	30	175	**
Standard	5/8	+0, -3/64	5/64	+1/64	36	165	**
Standard	5/8	+0, -3/64	5/64	+1/64	48	140	**
Standard	5/8	+0, -3/64	5/64	+1/64	60	120	**
Standard	5/8	+0, -3/64	5/64	+1/64	72	100	**
Standard	3/4	+0, -3/64	3/32	+1/64	8	210	100
Standard	3/4	+0, -3/64	3/32	+1/64	10	210	100
Standard	3/4	+0, -3/64	3/32	+1/64	12	205	100
Standard	3/4	+0, -3/64	3/32	+1/64	14	200	100
Standard	3/4	+0, -3/64	3/32	+1/64	16	195	100
Standard	3/4	+0, -3/64	3/32	+1/64	18	190	100
Standard	3/4	+0, -3/64	3/32	+1/64	24	180	100
Standard	3/4	+0, -3/64	3/32	+1/64	30	175	**
Standard	3/4	+0, -3/64	3/32	+1/64	36	165	**
Standard	3/4	+0, -3/64	3/32	+1/64	48	140	**
Standard	3/4	+0, -3/64	3/32	+1/64	60	120	**
Standard	3/4	+0, -3/64	3/32	+1/64	72	100	**
High Pressure	5/8	+0, -1/32	3/32	+1/64	8	435	320
High Pressure	5/8	+0, -1/32	3/32	+1/64	10	420	315
High Pressure	5/8	+0, -1/32	3/32	+1/64	12	410	305
High Pressure	5/8	+0, -1/32	3/32	+1/64	14	390	295
High Pressure	5/8	+0, -1/32	3/32	+1/64	16	375	285
High Pressure	5/8	+0, -1/32	3/32	+1/64	18	360	280
High Pressure	5/8	+0, -1/32	3/32	+1/64	20	350	270
High Pressure	5/8	+0, -1/32	3/32	+1/64	24	320	255
High Pressure	5/8	+0, -1/32	3/32	+1/64	30	280	**
High Pressure	5/8	+0, -1/32	3/32	+1/64	36	245	**
High Pressure	5/8	+0, -1/32	3/32	+1/64	48	195	**
High Pressure	5/8	+0, -1/32	3/32	+1/64	60	150	**
High Pressure	5/8	+0, -1/32	3/32	+1/64	72	100	**
High Pressure	3/4	+0, -1/32	3/32	+1/64	8	425	315
High Pressure	3/4	+0, -1/32	3/32	+1/64	10	410	310
High Pressure	3/4	+0, -1/32	3/32	+1/64	12	400	300
High Pressure	3/4	+0, -1/32	3/32	+1/64	14	385	290
High Pressure	3/4	+0, -1/32	3/32	+1/64	16	370	280
High Pressure	3/4	+0, -1/32	3/32	+1/64	18	355	275
High Pressure	3/4	+0, -1/32	3/32	+1/64	20	345	265
High Pressure	3/4	+0, -1/32	3/32	+1/64	24	315	250
High Pressure	3/4	+0, -1/32	3/32	+1/64	30	275	**
High Pressure	3/4	+0, -1/32	3/32	+1/64	36	240	**
High Pressure	3/4	+0, -1/32	3/32	+1/64	48	190	**

Type	OD Size	Tol	Wall	Maximum Recommended Working Pressure (psi)			
				Tol	Length	Temp. to 150°F	Steam Boiler
High Pressure	3/4	+0, -1/32	3/32	+1/64	60	145	**
High Pressure	3/4	+0, -1/32	3/32	+1/64	72	100	**
Redline	5/8	+0, -1/32	3/32	+1/64	8	370	285
Redline	5/8	+0, -1/32	3/32	+1/64	10	345	280
Redline	5/8	+0, -1/32	3/32	+1/64	12	335	280
Redline	5/8	+0, -1/32	3/32	+1/64	14	325	275
Redline	5/8	+0, -1/32	3/32	+1/64	16	315	270
Redline	5/8	+0, -1/32	3/32	+1/64	18	305	265
Redline	5/8	+0, -1/32	3/32	+1/64	20	290	265
Redline	5/8	+0, -1/32	3/32	+1/64	24	265	255
Redline	5/8	+0, -1/32	3/32	+1/64	30	235	**
Redline	5/8	+0, -1/32	3/32	+1/64	36	205	**
Redline	5/8	+0, -1/32	3/32	+1/64	48	165	**
Redline	5/8	+0, -1/32	3/32	+1/64	60	125	**
Redline	5/8	+0, -1/32	3/32	+1/64	72	90	**
Redline	3/4	+0, -1/32	3/32	+1/64	8	360	280
Redline	3/4	+0, -1/32	3/32	+1/64	10	340	275
Redline	3/4	+0, -1/32	3/32	+1/64	12	330	275
Redline	3/4	+0, -1/32	3/32	+1/64	14	320	270
Redline	3/4	+0, -1/32	3/32	+1/64	16	310	265
Redline	3/4	+0, -1/32	3/32	+1/64	18	300	260
Redline	3/4	+0, -1/32	3/32	+1/64	20	285	260
Redline	3/4	+0, -1/32	3/32	+1/64	24	260	250
Redline	3/4	+0, -1/32	3/32	+1/64	30	230	**
Redline	3/4	+0, -1/32	3/32	+1/64	36	200	**
Redline	3/4	+0, -1/32	3/32	+1/64	48	160	**
Redline	3/4	+0, -1/32	3/32	+1/64	60	125	**
Redline	3/4	+0, -1/32	3/32	+1/64	72	90	**

** Maximum recommended length in this service is 24."



WATER GAUGES AND LIQUID LEVEL GAUGES

Repair Kits

The standard* repair kits contain glass packing, stem packing, friction washers, seat washers, and drain washer applicable to the particular valve. Three types of glass packing, EPDM rubber, Hypalon®, and Virgin Teflon®, are included in the standard repair kit. For oil related service, Fluorelastomer (Viton®) glass gasket sets are available. For severe applications, graphite glass gaskets and stem packing sets are available for each model.

REPAIR KIT ORDERING INFORMATION

20	-	001	-	01
DESIGNATION		KIT TYPE		KIT NUMBER
20-00 = Water Gauge Repair Kit		1 = Standard All 2 = Viton Gaskets Only 3 = Graphite Gaskets Only		01 = 08 02 = 09 03 = 10 04 = 11 05 = 12 06 = 13 07 = 14

EXAMPLES:

- *20-001-01 = Standard Kit described above
- 20-002-01 = Viton Glass Gaskets Only
- 20-003-01 = Graphite Glass Gaskets Only

REPAIR KIT APPLICATIONS

Kit	Applications
20-001-01 20-003-01	20-101, 20-102, 20-104, 20-105, 20-150, 20-151, 20-405, 20-406, 20-407, 20-408, 20-410, 21-101, 21-102, 21-104, 21-105, 21-150, 21-151,
20-001-02 20-003-02	20-201, 20-202, 20-204, 20-205, 20-250, 20-251, 20-304, 20-305, 20-350, 20-351, 20-604, 20-605, 20-804, 20-805, 21-204, 21-205, 21-250, 21-251, 25-201, 25-202, 25-204, 25-205, 25-404, 25-405, 25-501, 25-502
20-001-03 20-003-03	20-207, 20-208, 20-253, 20-254, 20-307, 20-308, 20-353, 20-354, 25-207, 25-208, 25-407, 25-408, 25-504, 25-505
20-001-04 20-003-04	20-601, 25-601
20-001-05 20-003-05	20-602, 25-602
20-001-06 20-003-06	20-703, 20-704, 20-713, 20-714
20-001-07 20-003-07	23-401, 23-402, 23-450, 23-451
20-001-08 20-003-08	20-405, 20-406, 20-407, 20-408
20-001-09 20-003-09	23-404, 23-405, 23-453, 23-454
20-001-10 20-003-10	23-651, 23-654
20-001-11 20-003-11	24-301, 24-302, 24-350, 24-351, 24-450, 24-451
20-001-12 20-003-12	24-304, 24-305, 24-353, 24-354, 24-453, 24-454
20-001-13 20-003-13	24-601, 24-651, 24-751, 24-851
20-001-14 20-003-14	24-602, 24-652, 24-752, 24-852
20-002-01	20-101, 20-102, 20-104, 20-105, 20-150, 20-151, 20-201, 20-202, 20-204, 20-205, 20-250, 20-251, 20-304, 20-305, 20-350, 20-351, 20-405, 20-406, 20-407, 20-408, 20-410, 20-601, 20-604, 20-605, 20-703, 20-704, 20-713, 20-714, 20-804, 20-805, 21-101, 21-102, 21-104, 21-105, 21-150, 21-151, 21-204, 21-205, 21-250, 21-251, 23-651, 23-654, 25-201, 25-202, 25-204, 25-205, 25-404, 25-405, 25-501, 25-502, 25-601
20-002-02	20-207, 20-208, 20-253, 20-254, 20-307, 20-308, 20-353, 20-354, 25-207, 25-208, 25-407, 25-408, 25-504, 25-505, 20-602, 25-602
20-002-03	23-401, 23-402, 23-450, 23-451, 24-301, 24-302, 24-350, 24-351, 24-450, 24-451, 24-601, 24-651, 24-751, 24-851
20-002-04	23-404, 23-405, 23-453, 23-454, 24-304, 24-305, 24-353, 24-354, 24-453, 24-454, 24-602, 24-652, 24-752, 24-852

Hypalon®, Teflon® and Viton® are registered trademarks of DuPont.



For additional information, submittal sheets and manuals, visit www.apollovalves.com

Customer Service (704) 841-6000

WATER GAUGES AND LIQUID LEVEL GAUGES

Repair Kits

SELECTION INSTRUCTIONS

It is helpful to determine the following information when ordering a repair kit.

- Model number (if not available describe gauge, i.e. material, # guard rods, NPT size, etc.)
- Glass O.D. and type
- Handle type
- Service media, temperature, and pressure

If you know the model number just examine the "Repair Kit Applications" chart to select kit number for your valve. To order the standard kit, or Viton®, or graphite gaskets, assemble the ordering matrix for the desired kit number.

If you are unable to determine model number please determine the above information and call customer service for assistance.

For replacement glass please determine the above information in addition to the "L" dimension and call customer service. "L" dimension (center to center height of water gauge inlets).

WATER GAUGE & GAUGE GLASS REPAIR KIT INSTRUCTIONS

Only properly trained personnel should install, maintain and repair water gauge glass and connections. Remember to wear safety gloves and glasses during installation/repair. Before installing, make sure all parts are free of chips and debris.

DISASSEMBLY/ASSEMBLY

- 1 Close water gauge valves. If necessary drain vessel to eliminate leakage during repair. Drain gauge glass using drain valve or plug.
- 2 Completely loosen both glass packing nuts.
- 3 Gently raise gauge glass until bottom of gauge glass clears lower fitting.
- 4 Using a wrench attached to the hex flats on the upper fitting, lift glass and packing nut then rotate the fitting and glass 1/8 turn counterclockwise.
- 5 Carefully remove the gauge glass from the upper fitting. Remove all glass packing, packing nuts, washers and packing glands, noting their positions on the glass.
- 6 Clean and inspect gauge glass and fittings for any wear, erosion, cracks or debris. Any damaged components must be replaced.

- 7 If it is desired, the stem packing can be replaced by removing the handle(s) then the stem packing nut. Remove old packing and stem packing washer if applicable. Install new packing in stem packing nut and reuse stem packing washer as applicable.

- 8 To replace seat washers (where applicable) the system must be drained. After removing the stem packing nut reinstall handle and remove stem by opening valve. Cut off old seat washer and install new seat washer using appropriate size tube driver.

- 9 Install stem until it seats. Remove handle and install stem packing nut with packing inside. Tighten stem packing nut until snug using wrench.

- 10 Place glass packing nut, friction washer (or packing gland) and retaining ring, depending upon the model), and new glass packing, in the same order as found, on to both ends of the gauge glass. Push both packings about an inch up the gauge glass.

- 11 Gently insert one end of the glass into the top gauge fitting. Keeping the glass inside the top fitting, gently rotate the top gauge fitting clockwise, using wrench on valve hex flats, until vertically aligned with the bottom gauge fitting. Insert glass into bottom fitting until glass bottoms out on the shoulder inside the bottom fitting.

- 12 Carefully raise glass about 1/16" and slide lower glass packing down until the glass packing bottoms out. **DO NOT** allow the glass to remain in contact with any metal!

- 13 Carefully slide upper glass packing up as far as possible.

- 14 Hand tighten both glass packing nuts, then tighten 1/2 turn more by wrench. Tighten only enough to prevent leakage. **DO NOT OVER TIGHTEN!** If any leakage should occur, tighten slightly, a quarter turn at a time, checking for leakage after each turn.

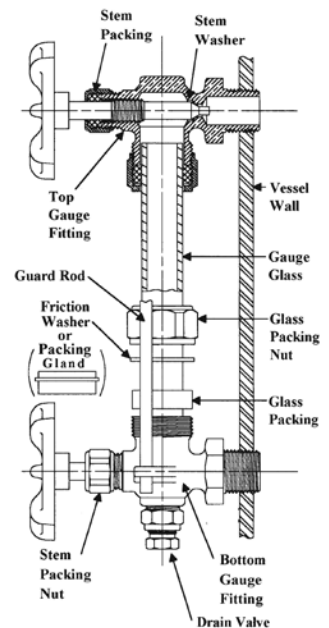

WATER GAUGES AND LIQUID LEVEL GAUGES

Glossary

AUTOMATIC / ASME AUTOMATIC / NON-AUTOMATIC WATER GAUGES:

An automatic water gauge is one that is equipped with ball checks in the valve body. In the event of glass breakage, these ball checks move horizontally, automatically seat to close the valves, shut off the flow of fluid, and help reduce the risk of property damage and/or personal injury from released fluid. An ASME automatic water gauge has a ball check in the bottom valve body that rises vertically to seat, and has a ball check in the top valve body that moves horizontally to seat.

BALL VALVE:

A bronze or stainless steel on-off valve utilizing a cored chrome-plated brass or stainless steel ball and Teflon seals. Easier to use than plug drains, pet cocks, or needle drains.

CENTER TO CENTER:

The distance between the centers of the two N.P.T. tapped holes in the vessel where the water gauge is to be attached.

CHAIN LEVER:

A lever handle activated by pulling a chain. Use for high, hard to reach installations.

EPDM:

Ethylene propylene rubber gauge glass packing, for temperatures -20°F to 350°F. Recommended for water, steam, silicone oils, ketones (MEK, acetone, etc...), alcohol, and brake fluid. Unsuitable for petroleum oils.

FRICION WASHER:

The thin metal washer used to separate a packing from a metal surface to reduce friction. This in turn reduces the risk of inducing damaging torsional stress in the packing or gauge glass (torsional stress may reduce the useful life of the packing and gauge glass.)

GAUGE GLASS:

The transparent part of a water gauge assembly connected directly to a boiler, below and above the waterline, to indicate the level of water in the boiler.

GLASS PACKING:

The larger soft rubber-like or plastic ring, when compressed, provides a seal between the gauge glass and the valve body.

GLASS PACKING NUT:

The metal nut that the tubular gauge glass passes through. Tighten this nut to effect a seal between the glass packing and the gauge glass.

GRAPHITE:

Gaskets formed using graphite yarn. Suitable for temperatures up to 1200°F. Use when necessary for extended service at elevated temperatures.

GUARD RODS:

Guard rods are metal rods, mounted to the valve bodies or guard rod flange, that rise vertically to help protect the gauge glass from accidental breakage.

HANDWHEEL:

The aluminum or plastic (composition) handle. Also see chain lever.

HYPALON®:

TFE (an endless Tetrafluorethylene Aramid) gauge glass packing ring w/Hypalon as a binder, suitable for temperatures from -20°F to 450°F. More difficult to seal than softer EPDM or Viton™ Rubbers. Use only when needed for superior acid resistance.

NEEDLE DRAIN:

A two piece drain (requires a wrench) that allows fluid to flow through an axial outlet.

PACKING GLAND:

The shouldered metal ring used in some models to supply extra compression to the gauge glass packing.

PET COCK:

A brass or bronze tapered plug, metal seated on-off valve.

PLUG DRAIN:

A tapped opening (together with a threaded plug and drain seal) in the bottom of the lower valve body, to allow fluid to drain from the water gauge. This type drain requires a wrench for installation/removal. This type drain is not recommended for hazardous fluids (the fluid may come into contact with the operator).

SEAT WASHER:

The small white Teflon™ plastic ring sometimes used to seal the metal valve seat.

STEM PACKING:

The smaller soft rubber-like or plastic ring, when compressed, provides a seal between the valve stem and the valve body.

STEM PACKING NUT:

The metal nut that the valve stem passes through. Tighten this nut to effect a seal between the stem packing and the stem.

STEM PACKING WASHER:

The thin metal washer on the stem that serves as a friction washer and protects against extrusion of the packing.

TEFLON®:

Virgin PTFE fluoropolymer gauge glass packing or seat washer, for temperatures up to 450°F. More difficult to seal than Hypalon™. Use only when needed for more chemical resistance than Viton™ at elevated temperatures. Not recommended for hot fluorine, oxygen difluoride, or chlorine trifluoride.

TUBULAR GAUGE GLASS PROTECTOR:

A metal or impact-resistant plastic tube that fits over the gauge glass, to protect the glass from accidental breakage, and to help minimize the risk of personal injury and/or property damage. The use of a glass protector, where available, is recommended for all water gauge applications.

VITON®:

Fluorocarbon rubber (FKM) gauge glass packing, for temperatures -15°F to 400°F (up to 600°F for short periods.) Use for superior resistance at elevated temperatures. Recommended for petroleum oils, silicone oils, halogenated hydrocarbons (carbon tetrachloride, trichloroethylene), acids. Unsuitable for ketones (MEK, acetone), amines, anhydrous ammonia, hot hydrofluoric or chlorosulfonic acid. * *Not recommended for use with steam.*

WATER GAUGE:

The gauge glass and its fittings for attachment.



For additional information, submittal sheets and manuals, visit www.apollovalves.com

Customer Service (704) 841-6000

WATER GAUGES AND LIQUID LEVEL GAUGES

OTHER APOLLO LITERATURE FOR YOUR SPECIFICATION LIBRARY



Commercial Products Catalog



Backflow Prevention Catalog



APOLLOXPRESS® Catalog

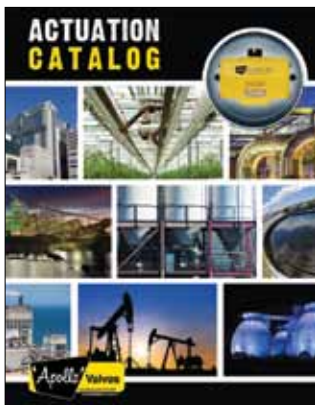

Actuation Catalog

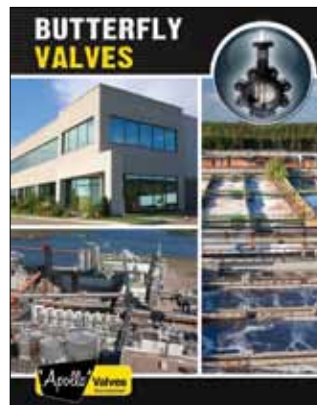

Butterfly Valve Catalog

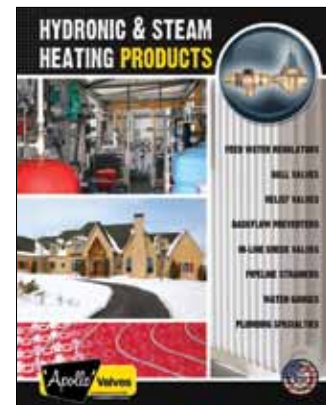

Hydronic & Steam Heating Products Catalog

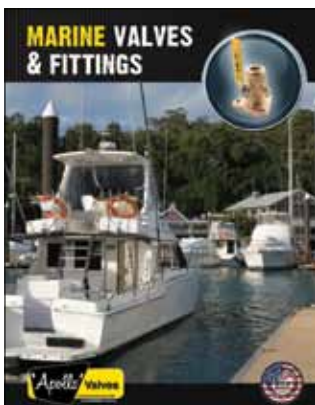

Marine Catalog

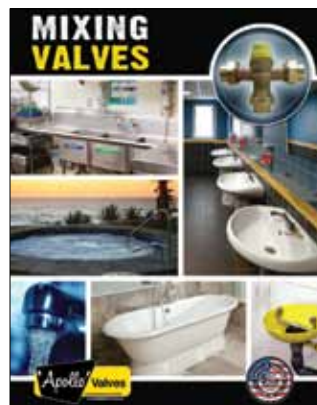

Mixing Valve Catalog

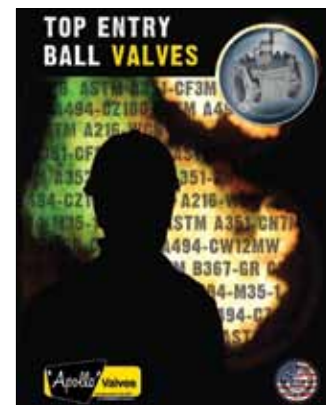

Top Entry Catalog

WATER GAUGES AND LIQUID LEVEL GAUGES

WARRANTY AND LIMITATIONS OF LIABILITY

Conbraco Industries, Inc. warrants, to its initial purchaser only, that its products which are delivered to this initial purchaser will be of the kind described in the order or price list and will be free of defects in workmanship or material for a period of FIVE years from the date of delivery to you, our initial purchaser. This warranty applies to Apollo brand product with "Made in the USA" markings only.

Should any failure to conform to this warranty appear within FIVE years after the date of the initial delivery to our initial purchaser, Conbraco will, upon written notification thereof and substantiation that the goods have been stored, installed, maintained and operated in accordance with Conbraco's recommendations and standard industry practice, correct such defects by suitable repair or replacement at Conbraco's own expense.

APOLLO INTERNATIONAL PRODUCTS: Conbraco Industries, Inc. warrants its International products, to its initial purchaser only, that its international products which are delivered to this initial purchaser will be of the kind described in the order or price list and will be free of defects in workmanship or material for a period of TWO years from the date of delivery to you, our initial purchaser.

THIS WARRANTY IS EXCLUSIVE AND IS IN LIEU OF ANY IMPLIED WARRANTY OF MERCHANTABILITY, FITNESS FOR A PARTICULAR PURPOSE OR OTHER WARRANTY OF QUALITY, WHETHER EXPRESSED OR IMPLIED, EXCEPT THE WARRANTY OF TITLE AND AGAINST PATENT INFRINGEMENT. Correction of non-conformities, in the manner and for the period of time provided above, shall constitute fulfillment of all liabilities of Conbraco to our initial purchaser, with respect to the goods, whether based on contract, negligence, strict tort or otherwise. It is the intention of Conbraco Industries, Inc. that no warranty of any kind, whether expressed or implied shall pass through our initial purchaser to any other person or corporation.

LIMITATION OF LIABILITY: Conbraco Industries, inc. SHALL NOT UNDER ANY CIRCUMSTANCES BE LIABLE FOR SPECIAL OR CONSEQUENTIAL DAMAGES SUCH AS, BUT NOT LIMITED TO, DAMAGES OR TO LOSS OF OTHER PROPERTY OR EQUIPMENT, LOSS OF PROFITS OR REVENUE, COST OF CAPITAL, COST OF PURCHASED OR REPLACEMENT GOODS, OR CLAIMS OF CUSTOMERS OF OUR INITIAL PURCHASER. THE REMEDIES OF OUR INITIAL PURCHASER, AND ALL OTHERS, SET FORTH HEREIN, ARE EXCLUSIVE, AND THE LIABILITY OF CONBRACO WITH RESPECT TO SAME SHALL NOT, EXCEPT AS EXPRESSLY PROVIDED HEREIN, EXCEED THE PRICE OF THE GOODS UPON WHICH SUCH LIABILITY IS BASED.

* It is the end user's responsibility to confirm that items intended for use satisfy local codes and standards.



APOLLO VALVES SALES MANAGERS & INTERNATIONAL REPS

	AREAS COVERED	EMAIL	PHONE	FAX	
REGIONAL SALES DIRECTORS					
	Brian Blalock	Commercial	brian.blalock@conbraco.com	704-614-3744	704-841-6021
	Mike Green	Industrial	mike.green@conbraco.com	704-841-6039	704-841-6021
REGIONAL SALES MANAGERS – COMMERCIAL					
COMMERCIAL	Kevin Ashworth	Mid-Atlantic	kevin.ashworth@conbraco.com	757-272-6200	
	Steve Brown	Western	steve.brown@conbraco.com	425-985-5095	253-862-3548
	Andy Fretz	Canada	andy.fretz@conbraco.com	647-281-3161	905-761-6666
	Ben Lauetta	Northeast	ben.lauetta@conbraco.com	518-795-4629	
	Sean Perry	Backflow Prevention Products	sean.perry@conbraco.com	704-641-9167	
	Nick Shelley	South Central & Florida	nick.shelley@conbraco.com	214-790-4157	
	Bill Stanton	North Central	bill.stanton@conbraco.com	262-227-0584	
REGIONAL SALES MANAGERS – INDUSTRIAL					
INDUSTRIAL	JR Fortenberry	Mountain States	jr.fortenberry@conbraco.com	480-824-8288	
	Ken Griffin	Southeast	ken.griffin@conbraco.com	704-621-9296	704-841-6021
	Sanford Pauly	Central	sanford.pauly@conbraco.com	513-716-7772	513-321-7717
	James Saldivar	South Central	james.saldivar@conbraco.com	832-776-5547	
	Jim Todman	Canada	jim.todman@conbraco.com	905-407-8385	905-761-6666
	Skip Wilson	West	skip.wilson@conbraco.com	760-330-3293	775-854-5722
LASCO FITTINGS REGIONAL SALES MANAGERS – IRRIGATION					
IRRIGATION	David Beyer	Northeast	dbeyer@lascofittings.com	561-718-9379	
	Ben Freeman	Southeast	bfreeman@lascofittings.com	205-919-4944	
	Ron Modugno	West	rmodugno@lascofittings.com	661-910-5058	
	Jimmy White	Central	jwhite@lascofittings.com	731-234-2372	
	Rick Williamson	Eastern Specifications Manager	rwilliamson@lascofittings.com	386-451-2307	
INTERNATIONAL SALES REPS					
INTERNATIONAL	Jose Arias	Mexico	jose.arias@conbraco.com	1-956-631-4542	1-956-631-4681
	JR Jefferson	Central & South America	jr.jefferson@conbraco.com	1-832-220-3783	
	Luke Liu	China	luke.liu@conbraco.com	86-411-869-02498	
	Brencliff Group	Australia	petermcl@brencliff.com	61-0477-223110	
	Pegler Yorkshire	United Kingdom	adrian.byrne@peglyorkshire.co.uk	44-7740-449585	
	Pegler Yorkshire Mid East	Middle East/India	peter.pydubai@gmail.com	971-4-454-2353	971-4-454-2352
	Europe/Africa/Israel	Contact Customer Service	1-704-841-6000	1-704-841-6021	



For additional information, submittal sheets and manuals, visit www.apollovalves.com

current as of 1/18/13

Customer Service (704) 841-6000



SALES & CUSTOMER SERVICE: Phone: (704) 841-6000
 Fax: (704) 841-6020

www.apollovalves.com

APOLLO VALVES INDUSTRIAL & COMMERCIAL REPS

	AGENCY	AREAS COVERED	EMAIL	PHONE	FAX
SOUTHEAST REGION REPS					
SOUTHEAST	Mid South Marketing, Inc.	VA/MD/Washington DC/WV-East	michael.uecker@msmsales1.com	804-213-3801	804-213-3802
	Pro Marketing, Inc.	NC/SC/TN-East	sales@promarketinginc.net	864-578-4334	864-578-4889
	Spirit Group	FL (except Panhandle)	info@spiritgroupinc.com	407-291-6035	407-299-0378
	Tim Morales & Associates, Inc.	AL/FL Panhandle	sales@timmorales.com	251-602-8333	251-602-8339
	White Wolf Group	GA	info@whitewolfgroupinc.com	800-401-4870	888-908-9372
NORTHEAST REGION REPS					
NORTHEAST	Conroy & Griese Sales, Inc.	NY-East/NJ-North	iezzi52@aol.com	856-429-2660	856-429-2230
	Layden Company	NY-Upstate/PA-East/DE/NJ-South	joejr@laydencompany.com	610-363-6657	877-529-3361
	Urell, Inc.	MA/New England States	apollo@urell.com	617-923-9500	617-926-9414
NORTH CENTRAL REGION REPS					
NORTH CENTRAL	FourMation Sales	MN/ND/SD/WI-West	ryan@fourmationsales.com	763-420-6900	763-420-6993
	Marshall-Rodeno Heartland	NE/IA (Except River Counties)	dnaylor@marshallrodeno.com	303-575-6701	303-575-6706
	Midwest Spec	Northern OH, Western PA, WV	glsales@mwspec.com	330-538-0406	330-538-0410
	Midwest Spec	Southern OH, KY	rvsales@mwspec.com	800-755-7732	513-353-1589
	New Tech Marketing	Northern-IL/WI-East/IN/MI-UP/IA-River Counties	sales@new-techmarketing.com	630-378-4300	630-378-0343
	New Tech Marketing	MO/Southern IL/Northeast Kansas	ntm112@aol.com	618-394-0329	618-394-0427
	V.E. Sales Co., Inc.	MI (Except Upper Peninsula)	tomv@vesalesinc.com	586-774-7760	586-774-1490
SOUTH CENTRAL REGION REPS					
SOUTH CENTRAL	Marathon Flow Control	TX, OK, KS except Northeast, LA	sales@marathonflowcontrol.com	214-201-0100	214-201-0104
	NSC Marketing Group Inc.	OK	nsc_tulsa@sbcglobal.net	918-627-5340	918-664-1408
	PEPCO Sales & Marketing	TX	is@pepcosales.com	972-823-8700	972-823-8717
	Southern Marketing Group	MS/TN-West/AR/Bowie Cty.-TX	SMG49@bellsouth.net	901-547-0042	901-547-0035
WESTERN REGION REPS					
WESTERN	Elmco Duddy	CA - South	tduddy@elmcoduddy.com	626-333-9942	626-855-4811
	Gordon & Associates	WA, OR, AK, Northern counties ID	laura@gordonandassoc.com	360-566-1470	360-566-1478
	HC Fletcher	CA - North (AB 1953 Compliant Product & Fire Protection)	apollosales@hcfletcher.com	800-432-7047	949-660-9072
	Marshall-Rodeno Associated	ID-SE/NV-NE	dnaylor@marshallrodeno.com	303-575-6701	303-575-6706
	Romatec	CA - North PVF (Non AB 1953)	apollo@romatec.com	877-530-3530	661-588-3534
	Southwest Valves	CA (Waterworks)	c.burrell@southwestvalve.com	559-261-2703	559-261-2711
	Southwestern Industrial Sales Co.	Nevada-SW	eduardop@sw-ind.com	480-458-5838	480-458-5843
Spec Management Group	HI	msmarch4@cox.net	949-481-4225	949-487-0990	
CANADA REPS					
CANADA	Barclay Sales Ltd.	British Columbia	jblair@barclaysales.com	604-945-1010	604-945-3030
	Conbraco Industries, Canada	178 Pennsylvania Ave., Unit 1, Concord, Ontario L4K 4B1	conbraco.canada@conbraco.com	905-761-6161	905-761-6666
	D & M Mechanical Sales	Ontario/East	don@dandmsales.ca	613-384-7084	613-384-3407
	Dynamic Agencies, Ltd.	Saskatchewan	doug.dynamicage@sasktel.net	306-343-1901	306-343-1901
	J. Levandier Sales, Inc.	NS, NB, PE & NL	vickie@jlevandiersales.com	506-858-1615	506-858-1084
	Kern Industries, Ltd.	Alberta-North	colin@kernind.com	780-451-2056	780-454-6687
	Kern Industries Calgary, Ltd.	Alberta-South	laura.wood@kernindustries.ca	403-730-7791	403-239-8179
	Key to the North Sales Agency, Inc.	Ontario-North	hmes@keytothenorth.ca	705-524-6714	705-566-0148
	Task Controls, Inc.	Ontario	infotoronto@taskcontrols.com	416-291-3004	416-754-3481
	Tom Beggs Agencies Ltd.	Manitoba/NW Ontario	tba@mts.net	204-953-1900	204-774-6915
Ventes Techniques Nimattec, Inc.	Quebec	nimatec@nimatec.com	450-691-9427	450-691-4949	
IRRIGATION REPS					
IRRIGATION ONLY	Active Sales Northwest, Inc.	OR, WA, Western ID	stevek@activesalesnw.com	541-726-0320	541-726-1148
	Biz Sales Company	OH, KY, MI, IN, parts of PA, WV, WI	dzavelson@bizpvf.com	216-595-2888	216-595-2899
	Fourmation Sales	MN/ND/SD/WI-West	dean@fourmationsales.com	763-262-4700	763-262-4740
	Hall Marketing	AL, LA	hallmarketing@bellsouth.net	228-547-4637	228-832-6666
	J&J Midwest Sales	NE, IA, MO, KS	john@jandjmidwestsales.com	314-422-8419	
	John Hart	FL	jhart@lascofittings.com	772-595-7773	
	Larry Perkins	TX - Southern	lperkins@lascofittings.com	936-443-1096	
	Marel Enterprises	New England, NY, DE, MD, VA, DC, parts of PA & WV	marelenterprise@gmail.com	631-271-1718	631-427-8558
	Marsh & Moore	GA	jaustin@marshmoore.com	352-321-7499	904-827-8795
	Marshall-Rodeno Associated	CO/WY/MT/ID-SE/UT/NV-NE	dnaylor@marshallrodeno.com	303-575-6701	303-575-6706
	NSC Marketing Group Inc.	OK	nsc_tulsa@sbcglobal.net	918-627-5340	918-664-1408
	Pro Marketing, Inc.	NC/SC/TN-East	sales@promarketinginc.net	864-578-4334	864-578-4889
	Sherman Dobbs	TX - Northern	sdobbs@lascofittings.com	469-442-8510	972-417-9733
	Southern Marketing Group	MS/TN-West/AR/Bowie Cty.-TX	SMG49@bellsouth.net	901-547-0042	901-547-0035
	Spec Management Group	CA	msmarch4@cox.net	949-481-4225	949-487-0990
	Tim Morales & Associates, Inc.	AL	sales@timmorales.com	251-602-8333	251-602-8339
VPC Sales	AZ	chudson@vpcsales.com	661-257-3923	661-257-3928	